

TFD25 Ford Transit Custom V710/NXN/NRN 2024> Volkswagen Transporter T7 NVN/NSN 2024>

Item	Qty	Description	Item	Qty	Description
A	1	TFD25 Crossbar	D	2	M16 x 55 Bolts & Nyloc Nuts
B1	1	Left Hand Side Arm Assembly	E	2	M12 x 30 Bolts & 2 S/P Washers
B2	1	Right Hand Side Arm Assembly	F	4	M14 x 90 Bolts & Nyloc Nuts
C	4	Rear Panel Brackets	G	2	12 x 35 Flat Washers
			H	8	14 x 27 Flat Washers
P	4	Small Plastic Rivets	J	8	M10 Serrated Flange Nuts (75 Nm)

Bumper Removal:

1. Remove the mud guards where fitted, two plastic rivets inside the wheel arch and one push in clip on the lower edge from each side.
2. Vehicles without mudguards remove the one fixing inside the wheel arch from each side.
3. Remove the four fixings from the lower edge of the bumper. **Note:** - Vehicles with the additional centre panel this remains in place.
4. Disconnect the reversing sensor loom from the nearside located underneath the vehicle along the chassis rail and release the loom from the chassis.
5. Pull bumper out sideways and rearwards to remove. **Note:** - Only the lower half of the bumper is removed, the panels holding the reflectors stay in place.
6. Remove the impact beam, eight fixings. **Note:** - This is not refitted with the Towbar assembly.

Towbar Installation:

1. Insert items **B1** and **B2** inside the Chassis and loosely fix in place using items **E** and items **G**.
2. Loosely fix items **C** to the rear panel using items **F** and items **H**. **Note:** - When fitting **PRO-TFD25** there will be addition brackets and alternative fixings fitted at this stage which are not in this kit. Follow the installation guide provided with that kit carefully in conjunction with this one.
3. Loosely fix item **A** to items **C** using items **F** and items **H**. **Note:** - When fitting **PRO-TFD25** there will be addition brackets and alternative fixings fitted at this stage which are not in this kit. Follow the installation guide provided with that kit carefully in conjunction with this one.
4. Fully tighten all fixings ensuring the Towbar is rigid, square, and secure.
5. Remount the bumper and mudguards (if applicable) and plug the sensor loom back in.
6. Using items **D** secure your desired ball bracket and wiring plate (Not supplied in this kit) to item **A** and fully tighten the remaining fixings.

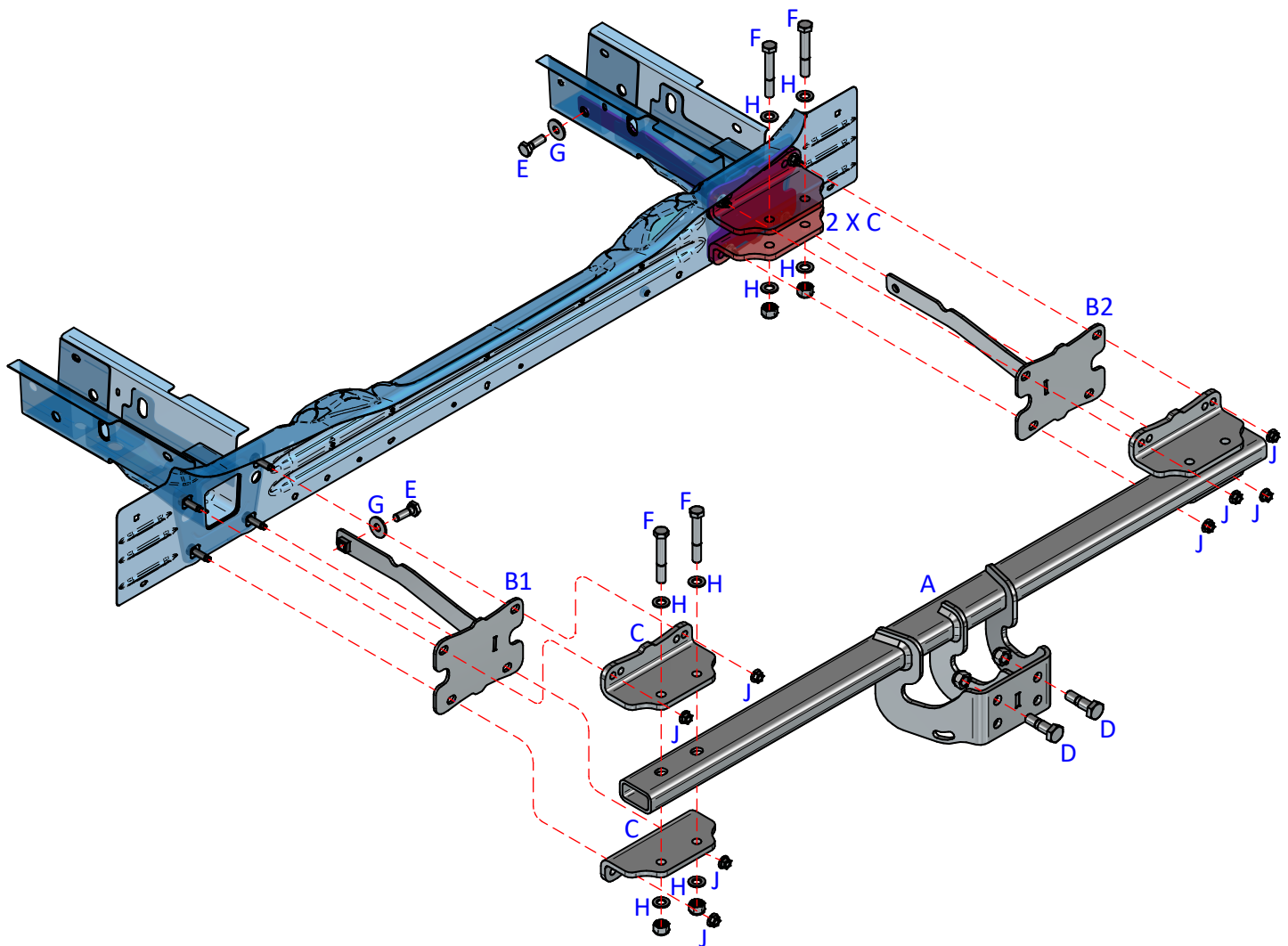

Notes:

1. For Torque settings see general notes overleaf.
2. Nose load limits and vehicle manufacturer's trailer / caravan weight limits must be observed.
3. We recommend the use of PRO-TOW Couplings with all our products.